

ALUFORM
INTERIOR SUPPLIES

TIMBER DOOR MACHINING
CUSTOM SIZE, FINISH & CORE CAPABILITIES

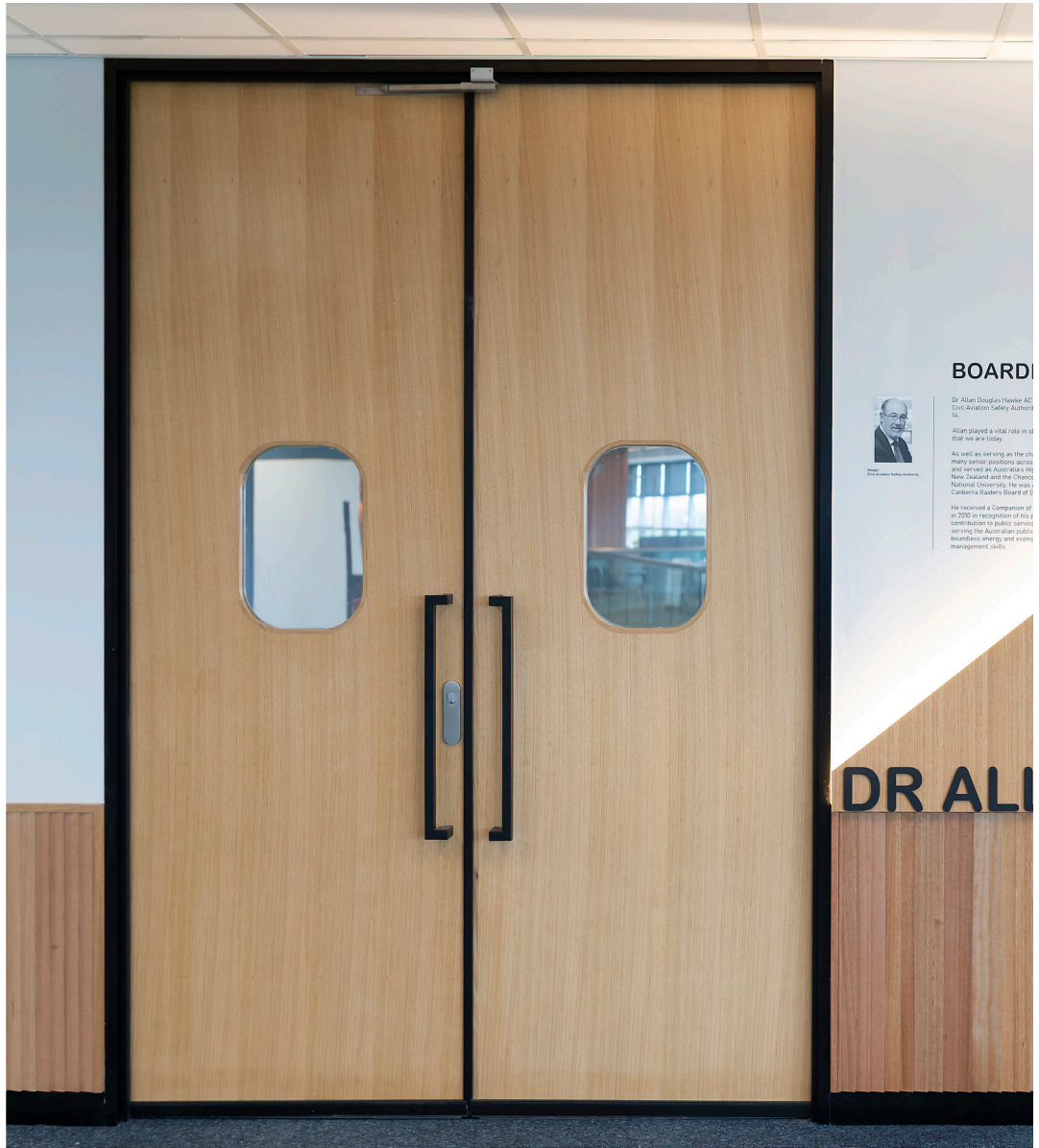





CASA, Canberra. Designed by The Mill: Architecture & Design. Featured: solid core & full glazed doors, Tasmanian Oak veneer.

STEP ONE: INTERNAL CORE SELECTION

CORE OPTIONS

- + Semi-solid MDF



- + Solid MDF



- + Solid Particleboard

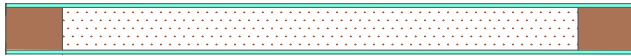

- + Solid Blockboard

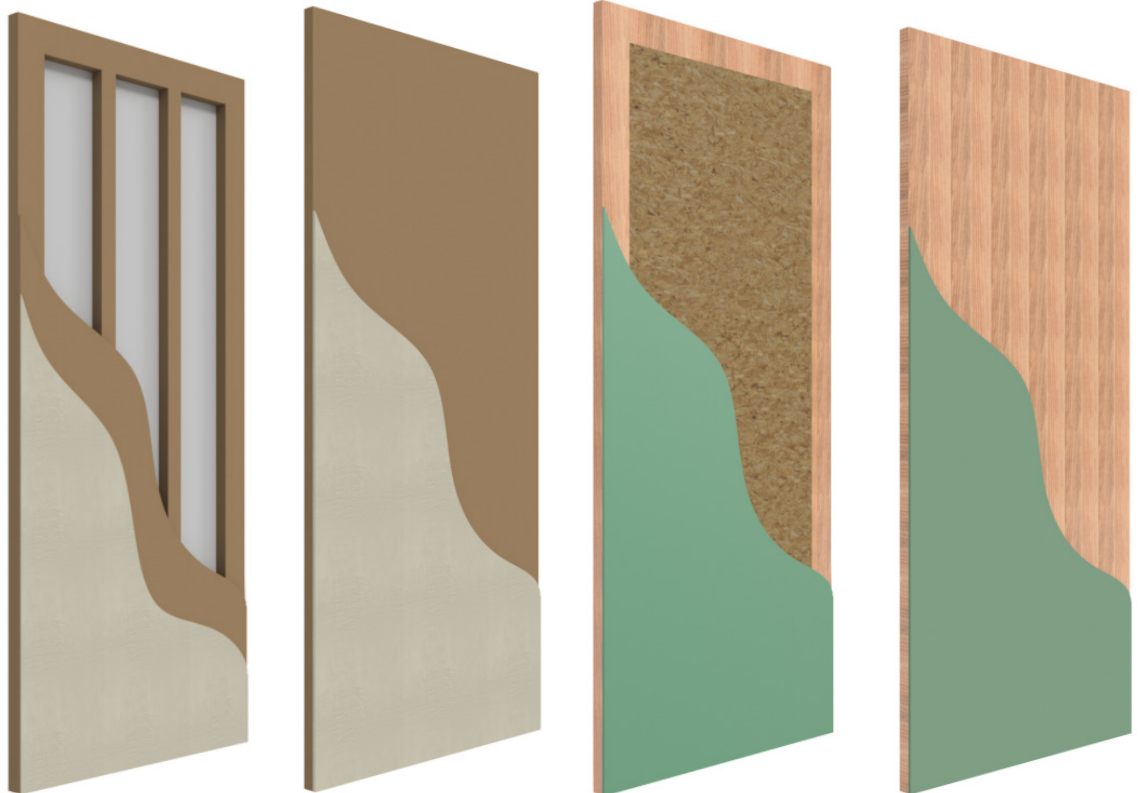
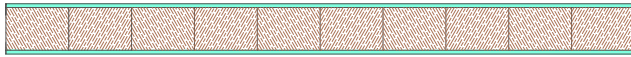



Ashurst Canberra. Design by Linear Designs. Featured: solid core & full glazed MDF doors with eucalypt veneer.

STEP TWO: FACE FINISH

AVAILABLE FINISHES

- + Pre-primed MDF
- + Duracote (paint-ready green skin)
- + Paint-grade plywood
- + Veneer or laminate, including:
 - [Laminex](#)
 - [Polytec](#)
 - [Navurban](#)
 - [Briggs](#)

STANDARD LEAD TIME

5 working days
5 working days
5 working days
Varies

Lead times are a guide only. Subject to change with stock availability and size of order.





PRE-MORTICE

Ready for immediate mortice lock installation.



SEAL GROOVE

Recessed drop seal groove to base of door. Available to suit a range of Raven and Kilargo seals.



SEAL END CAP

Machining to suit drop seal end caps. Radiused options available.



LATCH

Alternative to mortice, used for free passage doors.



PANEL CUT-OUT

Cut-out for Alu-vent or Alu-lite vision panel. Also available with beads for timber glazed vision panel.



ROLLER BOLT

Cut-out to facilitate immediate installation of roller bolts.

**Lead times are working days (Mon-Fri) and assume blank door is stocked or already available. For custom door lead time, refer "Face Finish", page 5.*

STEP THREE: MACHINING



GLAZING

Timber bead vision panels or full glazed timber doors. Regular and non-regular shapes available.



EDGESTRIPS & ABS

Solid timber edgestrips for veneer doors, and ABS edging for laminate doors.



FLUSH BOLT

Automatic flush bolt prep to edge of door.



TRANSOM CLOSER

Concealed door closer cut-out to top or bottom of door.



OTHER HARDWARE

Specialised hardware prep, including pivot closers, guides, rollers and more.



REBATE

13mm rebate on long edge of door, used for double timber door sets.



HUB Canberra. Design by M Moser Associates. Featured: solid core MDF doors with plywood face.

SECURE AREA DOORS (ZONE 3 - 5)

DOOR STRUCTURE

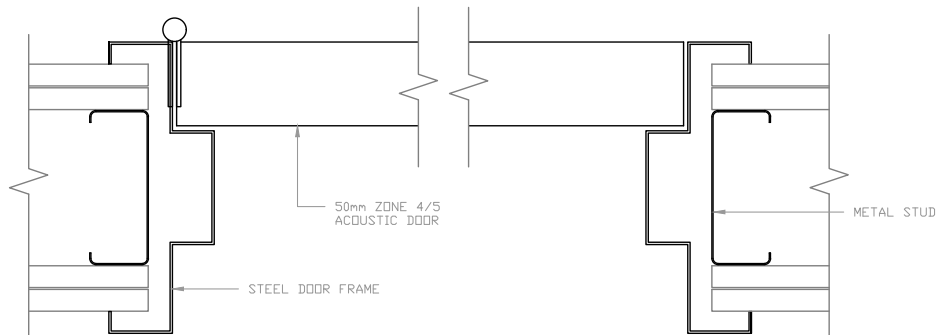
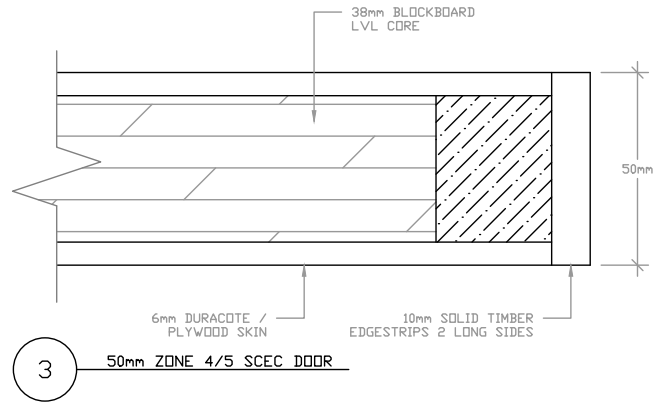
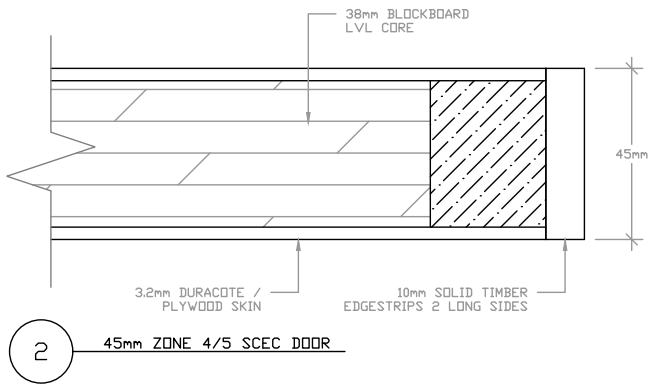

1 ZONE 4/5 DOOR/FRAME PLAN VIEW

- + Overall door thickness 45mm minimum
- + Core thickness 35mm minimum as per Scec requirements
- + Core constructed from cross-banded LVL timber blocks (blockboard)
- + Scec approved hardware available upon request
- + Veneer or laminate finish is additional to above structure diagram

LEAD TIME

- + 5-7 working days (not including veneer or laminate finish)



LDF INTERNAL PARTITION DOORS

LDF DOORS

LDF (light density fibreboard) doors are a solid core internal partition door kept in stock at our two locations: Queanbeyan and Seven Hills.

These doors are a great option for projects with short turnarounds, as they can be trimmed to any required size and used in a variety of internal applications.

While these doors are normally supplied oversize, we keep these in stock trimmed to exact sizes, and pre-morticed for convenience.





AEC Command Centre. Design by CK Architecture. Featured: solid core MDF doors with Aged Ash face.

DOOR/HARDWARE PACKAGES & FREIGHT

HARDWARE SUPPLY

Aluform supplies hardware from a variety of renowned manufacturers, including Assa Abloy, Dorma Kaba, Allegion, Raven, Kilargo and Zanda. Doors & hardware can be supplied to a project as a door-by-door package - doors will be labelled with the corresponding door number, and hardware packed in individual door lots.

This method saves considerable time on-site for large projects, making finding the right hardware very easy for contractors.

FREIGHT

Doors and hardware can be freighted anywhere in Australia via our network of couriers.









CANBERRA | HEAD OFFICE

PO BOX 6008
19 CARRINGTON STREET
QUEANBEYAN NSW 2620

SYDNEY | TRADE PICKUPS ONLY

15 PRINCE WILLIAM DRIVE
SEVEN HILLS NSW 2147

BRISBANE | BY APPOINTMENT ONLY

194 VARSITY PARADE
VARSITY LAKES QLD 4227

PHONE: 1800 995 817
EMAIL: sales@aluforminteriors.com.au
WEB: www.aluforminteriors.com.au

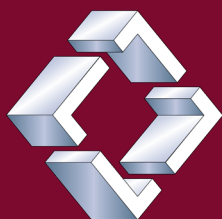

ALUFORM
INTERIOR SUPPLIES